

### Description

Body in ABS with galvanized steel base

Nickel plated magnet block

Operating voltage: 24 Vdc - Absorbed current: 70 mA

Fixed Holding force: > 55 Kg.

(on request reduced force to 20 Kg. - LF version)

Residual anti-magnetism pin on the electromagnet body

Connector with anti-disturb varistor

#### Without push button release

- Body in black colour ABS
- Body in grey colour RAL 7035 ABS

#### With push button release

- Body in black colour ABS
- Body in grey colour RAL 7035 ABS

Holding force adjustable from 10-50 Kg.- (i.e. 19001R)

Dual voltage version 24/48 Vdc

**Compliance:** CE EN1155

**Use:** door holding electromagnet for swing fire doors

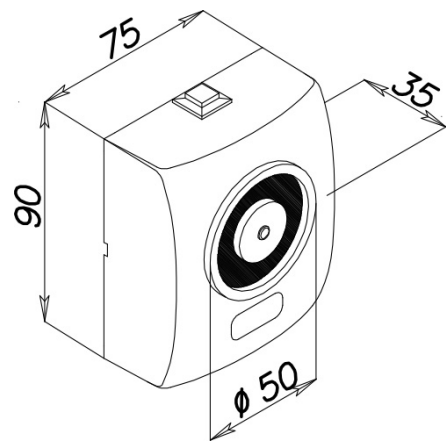

#### SWINGING ARMATURE

- Base in galvanized steel