

Description

Body in anodized aluminium with base in galvanized steel

Nickel plated magnet block

Operating voltage: 24 Vdc - Absorbed current: 70 mA

Fixed Holding force: > 55 Kg.

(on request reduced force to 20 Kg. - LF version),

Residual anti-magnetism pin on the electromagnet body

Connector with anti-disturb varistor

With push button release

- Body in silver colour anodized aluminium
- Body in black colour anodized aluminium
- Body in gold colour anodized aluminium
- Holding force adjustable from 10-50 Kg. - (i.e. 19002R)
- Dual voltage version 24/48 Vdc

Note: on request without push button release

Compliance: EN 1155

Use: hold open electromagnet for swing fire doors

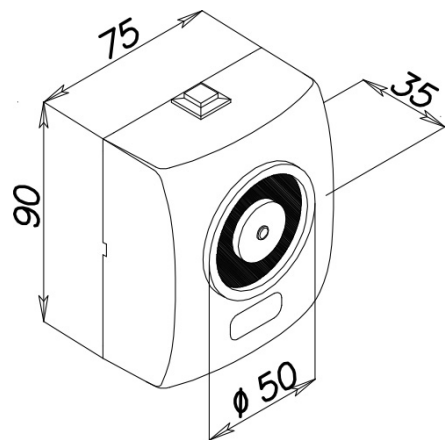

SWINGING ARMATURE

- Base in galvanized steel